

FEATURES

Veljan Seat Valves are body type mounting series VD4S and cartridge units series VCAR. The complete range of cartridges - body mounted VD4S and manifold mounted VCAR are sized from 3/8" to 1 1/2" permit flows from 180 lpm to 600 lpm and pressures up to 350 bar.

The interface porting on the subplate body versions follow CETOP, ISO and DIN standards and is dimensionally identical with the **VELJAN** VR4 series of pressure controls. Hence VD4S and VR4 valves can be conveniently used in combined circuitry.

The modular design is used in all valve sizes and the valves are used for a variety of functions :

- As a leak - proof directional control
- As a pressure control for the adjustment or limitation of the pressure
- As a check valve to obtain unidirectional flow
- As a throttle valve to control and limit the rate of flow

A variety of standard combinations of internal components are available along with additional options to suit special circuitry. These options are :

- Poppet stroke limiter :
to control maximum flow rate,
- Vent valve sandwiched :
to electrically control poppet operation,
- Seat area changes :
to vary operational characteristics,
- Shuttle valves :
To take pilot oil from Port A and Port B.

Advantages of VCAR cartridge valves are that when integrated with specially designed manifold blocks they offer space and cost savings in comparison with conventional piped circuit construction. A manifold design using cartridges is more sophisticated than utilising VD4S units and greater attention is required in the assembly of the cartridges into the manifolds.

Fast response and rapid frequency of operation even at the highest flow is achieved due to poppet design and precise ratio between its mass and stroke. The cast passages within the VD4S valve body when used with correctly designed manifolds ensure circuits in which pressure drop and oil turbulence is minimal.

Veljan seat valves and cartridges function to direct flow from port A to port B or vice - versa and their operation is dependent upon the effective pressure area and spring force on the poppet. The cracking pressure is proportional to the ratio of control area to seat or ring area. Pilot pressure at port X acting on the control area closes the seat valve, thus forces generated by cylinders or hydraulic motors can be decelerated to zero by controlling the differential pressure.

Acceleration or deceleration of fluid which the seat valve is controlling will take place whilst the valve is opening or closing and the time normally necessary to overcome overlap in conventional spool valves is eliminated. In addition to this improved response time, the action also ensures that the seat valve functions without introducing system pressure peaks or shocks and therefore machine cycle times may be reduced without detriment. Various seat valve combinations are manufactured to suit a wide variety of specialized industrial applications.

Cracking pressure depends on the area ratio of individual combination of spool and sleeve.

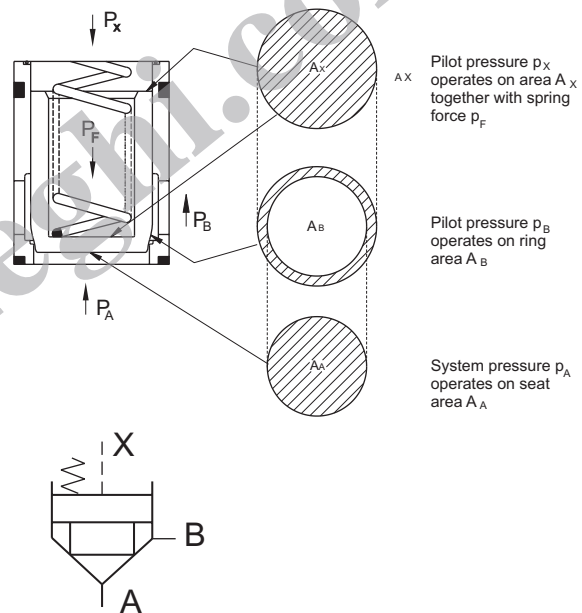

Example : With a ratio of 95% seat area to 5% ring area and a spring pressure = 2.2 bar then the following cracking pressures apply.

Direction of flow		Supposed pilot pressure P _x (bar)						
		0	9	15	30	100	250	330
PA	A → B	2.2	11.7	18.0	34	108	265	350
PB	B → A	42	222	342	>350 646	>350 2052	>350 5035	>350 6650

It is obvious that with flow direction B to A and a control (pilot pressure) at X of more than 15 bar, pressure in excess of maximum valve rating would be exceeded before the valve would open. Under static conditions the valve would still remain leakproof even at substantially higher pressure.

SV

Control functions

Typical functions which can be achieved in a circuit incorporating single or multiple seat valves

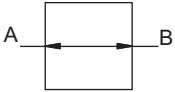
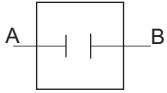
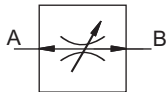
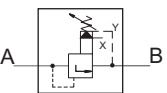
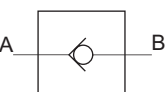
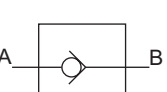
Function	Port X	P_x	Direction of flow	Notes
 <p>Way function</p>	Vented	$= 0$	$A \rightarrow B$ $B \rightarrow A$	Port X may be vented through a Veljan VVO1 solenoid operated three-way vent valve. Cracking pressure would then occur when P_A or P_B applied to the corresponding area equals the spring force.
 <p>Way function</p>	Connected with port A and B	$= P_A$ or $= P_B$	A and B blocked	Port X may be connected to both ports A and B through a shuttle valve. Then pressure at X will be equal to pressure at A or B depending upon which is greater.
 <p>Flow function</p>	Vented	$= 0$	$A \rightarrow B$ $B \rightarrow A$	Adjustable limiting stops can be fitted to limit spool opening and this produces a flow restriction in either direction.
 <p>Pressure function</p>	External pilot pressure	> 0	$A \rightarrow B$	Valve opening (cracking) can be controlled by application of external pilot pressure P_x .
 <p>Check function</p>	Connected with port B	$= P_B$	$A \rightarrow B$ Blocked B to A	Plug may be fitted between A and X leaving X connected to B (leak proof check valve function A).
 <p>Check function</p>	Connected with port A	$= P_A$	$B \rightarrow A$ Blocked A to B	Plug may be fitted between B and X leaving X connected to A (check valve function B not leakproof)

SV

Veljan Seat Valves are hydraulically operated poppet type cartridges designed to control flow direction either from port A to port B or vice versa depending upon the control circuit. The same modular design is used in all valve sizes and the valves and cartridges are used for a variety of functions:

- Either single or in a combination as a leak proof directional control.
- As a pressure control for the adjustment of limitations of pressure.
- As a check valve to obtain uni-directional flow.
- As a throttle valve to control and limit the rate of flow.

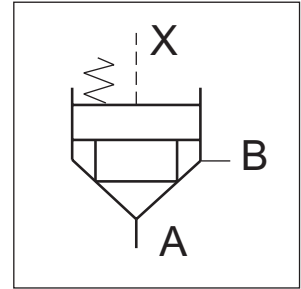

The basic element incorporated in both the body mounted and cartridge type (manifold) mounted series is the main cartridge comprising poppet spool, sleeve and spring. The wide range of optional combinations are based on an integrated system which offers easy modification to existing circuits incorporating the Veljan Seat valve/cartridge modules. Close manufacturing tolerances permit simple change or addition without special fitting.

SV

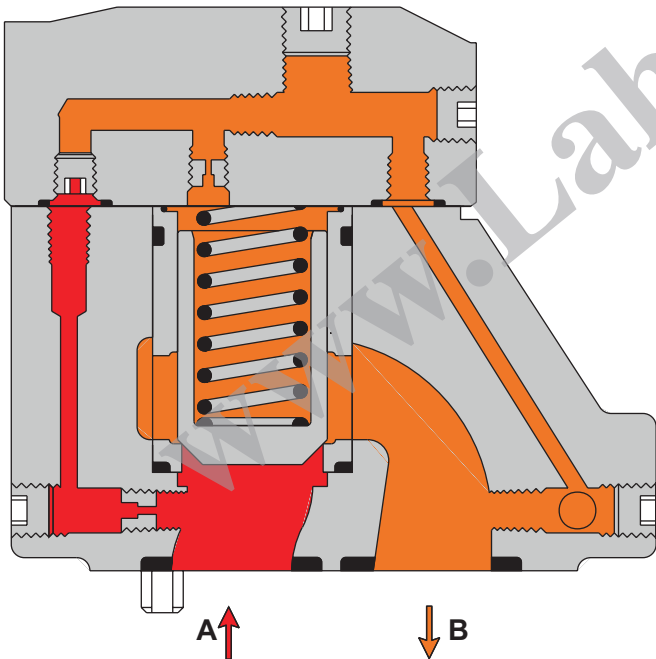

The body mounted valve series VD4S is available in 3/8", 3/4" and 1 1/2" sizes. It has application and production advantages when used in circuits on machines produced in small or medium batches. Since all pilot passages and control orifices are contained within the seat valve subplate mounted body, the manifold block on which they are mounted becomes a simple distributor block without the necessity for small drillings or close tolerances.

$\Delta p - q_v$ - Characteristics

Oil viscosity 38 cSt (228 SUS)
Oil temperature 50°C (122°F)

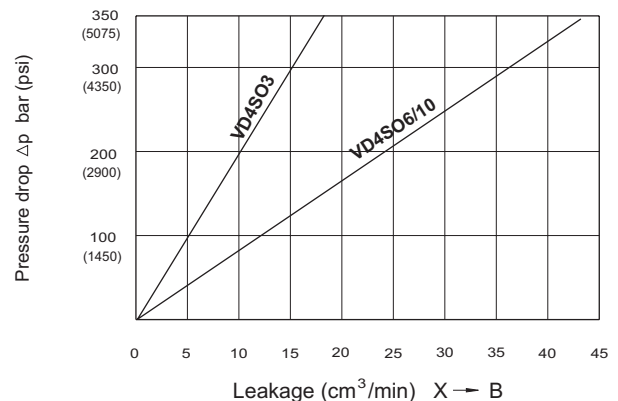
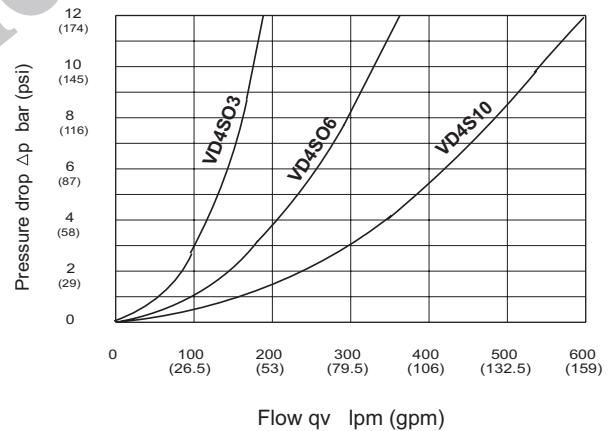

SPECIFICATIONS

General

Type of unit	:	Seat valve
Design	:	Poppet type
Type of mounting	:	Threaded, Subplate and Flange mounted
Mounting position	:	Optional
Port sizes	:	3/8", 3/4", 1 1/2"
Directional of flow	:	A→B or B→A
Ambient temperature	:	-20°C...+ 60°C (-4°F...+140°F)
Special working conditions	:	Consult VELJAN

Hydraulics

Operating Pressure range	:	
Port A, B, X	:	0 - 5000 psi (0 - 350 bar)
Port Y	:	0 (Without pressure to tank)
		VD4S03 (3/8") VD4S06 (3/4") VD4S10 (1 1/4")
Nominal flow gpm (lpm)	:	40 (150) 71 (270) 119 (450)
Maximum flow gpm (lpm)	:	48 (180) 95 (360) 159 (600)
Fluid Temperature Range	:	-18°C...+80°C (0°F...+176°F)
Viscosity Range	:	10 to 650 cSt (60 to 3900 SSU)
Optimum operating viscosity	:	30 cSt (180 SSU)
Pilot volume	:	VD4S03 VD4S06/10
- sleeve 95% seat area, spool 15° chamfer	:	1.00 cm ³ 4.75 cm ³
- sleeve 95% seat area, spool 45° chamfer	:	1.11 cm ³ 5.60 cm ³
- sleeve 60% seat area, spool 45° chamfer	:	0.77 cm ³ 3.75 cm ³

Adjustment

Type of control adjustment	:	Electrically by solenoid (VW01)
Nominal voltage	:	12,24,48 V DC
		115/230 V AC,50 cycles
		115/230 V AC,60 cycles
Permissible Voltage difference	:	+5... -10%
Maximum coil temperature	:	+155°C (239°F)
Input power	:	31W
Holding	:	78 VA
Inrush	:	264 VA
Relative operating period	:	100%
Type of protection	:	IP 65

ORDERING CODE

Series **VD4S 06 - 1 1 1 - 9 1 4 - 09 - W02 - B 1 *****

Size
 03 - 3/8" 06 - 3/4" 10 - 1 1/2"

Body mounting

- 3 - Subplate mounting VD4S 03/06/10
(Y₁ Port - 1/4" NPTF)
- 9 - Subplate Mounting VD4S 03/06/10
(Y₁ Port - 1/4" B.S.P.P.)
- 1 - Threaded body - VD4S03 = 1/2" NPTF
VD4S06 = 1" NPTF
(2 A Ports, 1B Port) X, Y₁ Port - 1/4" NPTF
- A - Threaded body - VD4S06 = 3/4" NPTF ;
VD4S10 = 1 1/4" NPTF
(1A Port, 1 B Port) X, Y₁ Port - 1/4" NPTF
- 6 - Threaded body - VD4S03 = 1/2" B.S.P.P. ;
VD4S06 = 1" B.S.P.P.
(2 A Ports, 1B Port) X, Y₁ Port - 1/4" B.S.P.P.
- D - Threaded body - VD4S06 = 3/4" B.S.P.P. ;
VD4S10 1 1/4" B.S.P.P.
(1 A Port, 1B Port) X, Y₁ Port - 1/4" B.S.P.P.
- 2 - Flange body - VD4S06
(2 A - Ports, 1 B - Port) X, Y₁ Port - 1/4" NPTF

Pilot Oil Line - Body

- 1 - Internal from A (A - X = ⊗1.2; B - Y = ○)
- 2 - External from X (A - X = ⊗; B - Y = ○)
- A¹⁾ - Internal from A (A - X = ⊗1.2; B - Y = ○)
- B¹⁾ - External from X (A - X = ⊗; B - Y = ⊗)
- C²⁾ - Internal from A and B (A - X = ⊗1.2; B - Y = ⊗1.2)
- D²⁾ - Internal from B (A - X = ⊗; B - Y = ⊗1.2)
- G²⁾ - External from Y (A - X = ⊗; B - Y = ⊗)

Pilot Oil Line - Cap

- 1 - PP = PD (Z = ⊗1.2; X - Y = ○; Y₁ = ⊗; Y = ⊗)
- 2³⁾ - Ext. PD from cap (Z = ⊗1.2; X - Y = ⊗; Y + Y₁ = ○; VV01 = ⊗)
- 3 - PP = PD (X = ⊗1.2; Y = ⊗)
- 4 - PP = PD (X = ⊗; Y = ⊗1.2)
- 5¹⁾ - External PD to subplate (Z = ⊗1.2; X - Y = ⊗; Y₁ = ⊗; Y = ○)
- 6³⁾ - Internal PD (Z = ⊗1.2; X - Y = ⊗; Y₁ = ⊗; Y = ○)
- C - PP = PD (Z = ⊗1.2; X - Y = ○; Y₁ = ⊗; Y = ○; X = ⊗)

Subplate mounting

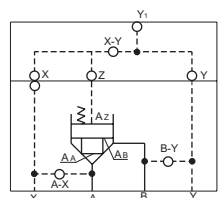

Threaded body

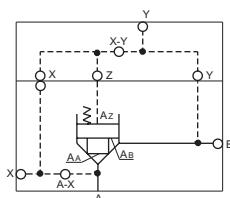

Legend :

- = Open
- ⊗ = Closed
- ⊗ = Orifice

1) = Subplate mounting & VV01 only

2) = Subplate mounting only

3) = With VV01 only

Modification

Seal Class

- 1 - Buna N (Standard)
- 5 - Viton

Design letter

Solenoid Voltage and current
(for VV01)

- W01 - 115V/60Hz AC GOR - 12V DC
- W02 - 230V/60Hz AC GOQ - 24V DC
- W06 - 115V/50Hz AC GOH - 48V DC
- W07 - 230V/50Hz AC

Accessories

- 09 - VV01 with manual override
- 10 - VV01 without manual override
- 11 - VV01 with manual override
- 12 - VV01 without manual override

De-energized; power component open



Energized; power component closed

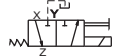

CA - Shuttle valve



DA - Shuttle valve



- CB - VV01 code 09 } And shuttle valve code CA
- CD - VV01 code 11 } And shuttle valve code CA
- DB - VV01 code 09 } And shuttle valve code DA
- DD - VV01 code 11 } And shuttle valve code DA

Spring (approx. cracking pressure in bar)

	Sleeve 1- AA=95%, AB=5%		Sleeve 3- AA=60%, AB=40%			
	A → B		A → B		B → A	
	VD4S03	VD4S06/10	VD4S03	VD4S06/10	VD4S03	VD4S06/10
1=	2.8	3.5	6.5	6.5	9.5	11.0
2=	0.5	0.5	1.0	1.0	1.5	1.7
3=	0.3	0.3	0.6	0.6	0.9	1.0
4=	2.2	2.2	4.0	3.5	5.5	6.0
5=	-	9.0	-	16.0	-	28.0
6=	1.2	1.2	2.0	2.2	3.0	3.8
7=	3.0	-	8.0	-	12.0	-

Spool type

- 1⁴⁾ - Closed bottom and 15° chamfer (P_z max = P_A + 20 bar)
- 2⁴⁾ - 0.8mm dia orifice at bottom and 15° chamfer (VD4S03)
1.2mm dia orifice at bottom and 15° chamfer (VD4S06 & VD4S10)
- 4 - Closed bottom & 45° chamfer
- B⁵⁾ - Throttle spool (10° chamfer)
- C⁵⁾ - Throttle spool (3° chamfer)

⁴⁾ = With sleeve 1 only

⁵⁾ = VD4S06, VD4S10 & sleeve 3 and springs 2,3,6 only

Sleeve type

- 1 - 95% seat area (A_A = 95%, A_B = 5%)
- 3 - 60% seat area (A_A = 60%, A_B = 40%)

RECOMMENDED SPRING, SPOOL, SLEEVE COMBINATIONS

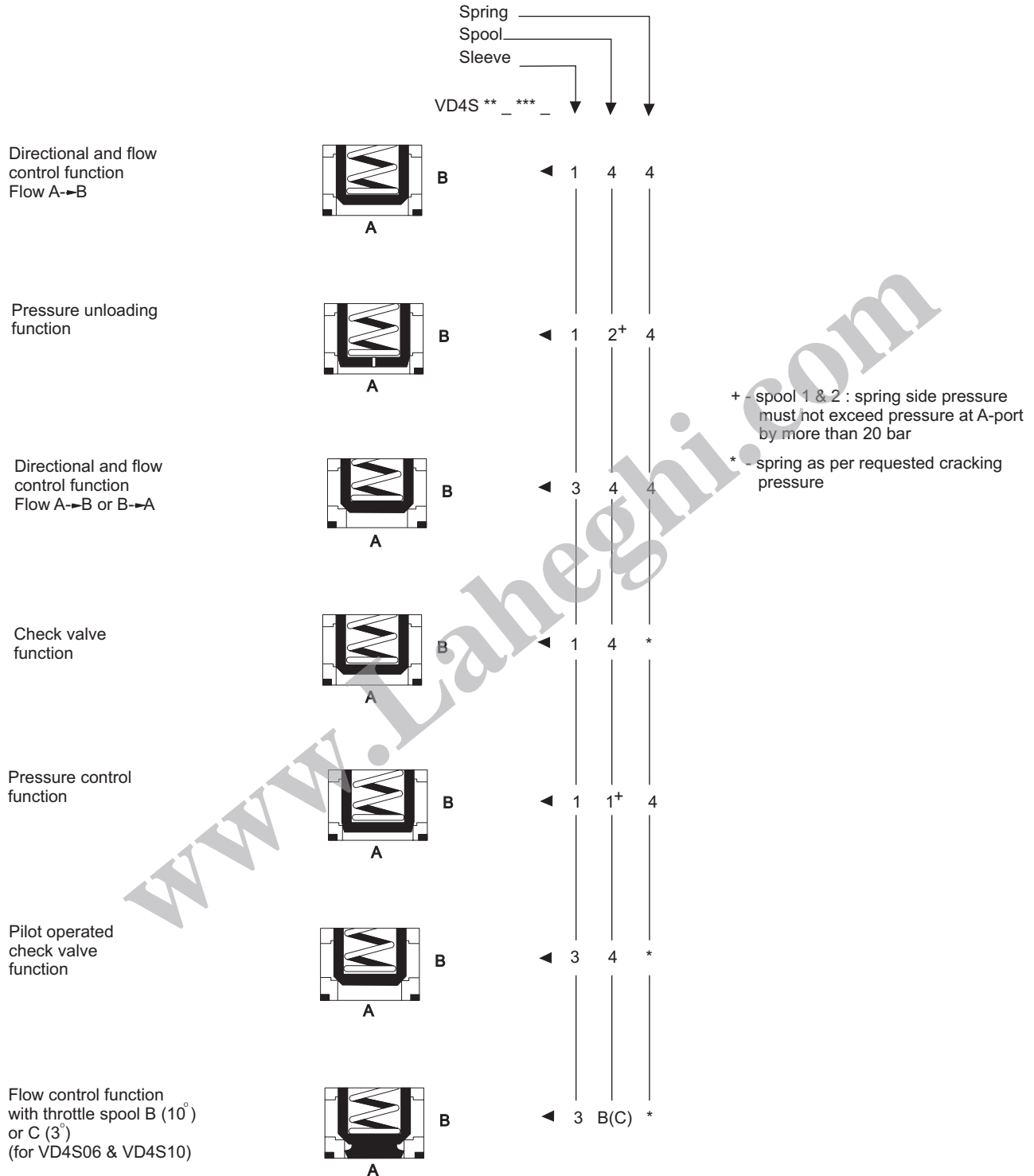

ORDERING CODE EXAMPLES

Subplate mounting

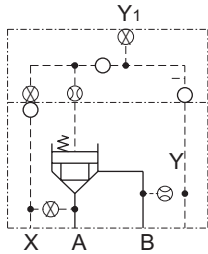

VD4S**-*DC
Pilot oil Y = internal from B

Subplate mounting

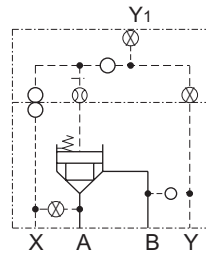

VD4S**-*21
Pilot oil X = external

Threaded body

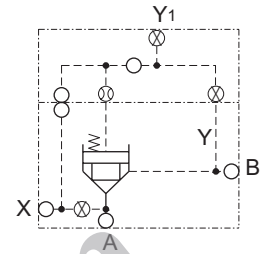

Subplate mounting

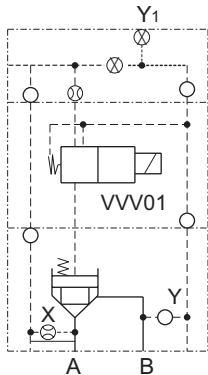

VD4S**-*16-***-
09 } with vent valve VVV01
10 }
11 }
12 }
Pilot oil X = internal from A
Drain Y = internal to B

Threaded body

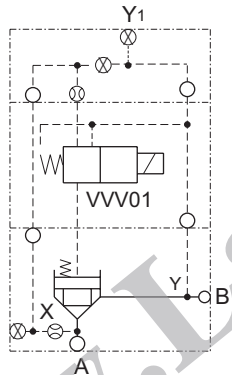

Subplate mounting

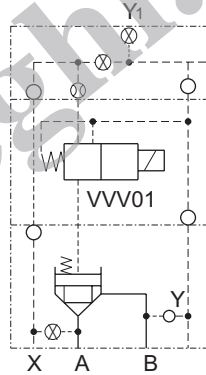

VD4S**-*26-***-
09 } With vent valve VVV01
10 }
11 }
12 }
Pilot oil X = external
Drain Y = internal to B

Threaded body

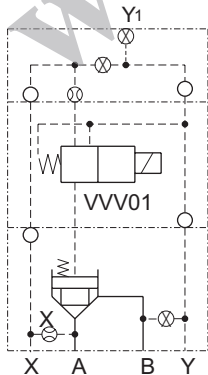
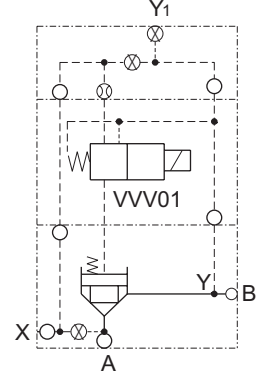

VD4S**-*A5-***-
09 } With vent valve VVV01
10 }
11 }
12 }
Pilot oil X = internal from A
Drain Y = external to subplate

Subplate mounting

Subplate mounting

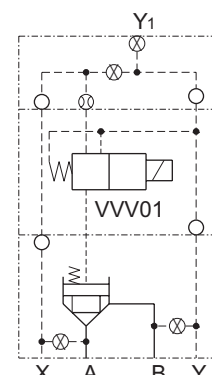

VD4S**-*B5-***-
09 } With vent valve VVV01
10 }
11 }
12 }
Pilot oil X = external
Drain Y = external to subplate

Subplate mounting

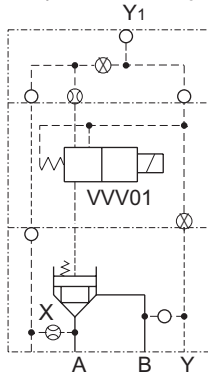

VD4S**-*12 -*** } with vent valve VVV01
 09
 10
 11
 12

Pilot oil X = internal from A
 Drain Y1 = external out of the cap

Threaded body

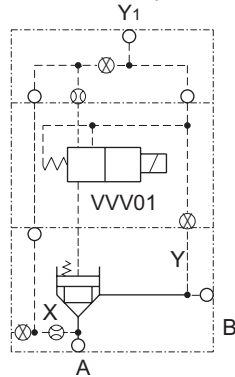

Subplate mounting

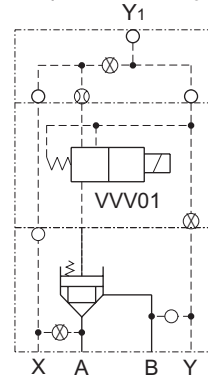

VD4S**-*22 -*** } with vent valve VVV01
 09
 10
 11
 12

Pilot oil X = external
 Drain Y1 = external out of the cap

Threaded body

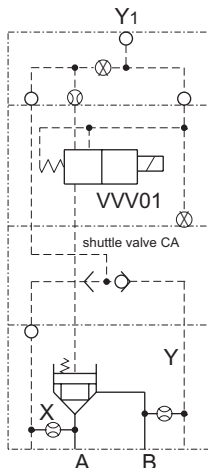
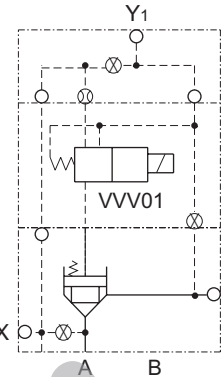

VD4S **-*C2 -*** } with shuttle valve CA
 CB }
 CD } and vent valve VVV01

Subplate mounting

Pilot oil
 = internal from A and B
 Drain Y1
 = external out of the cap

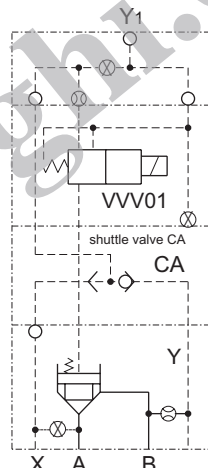

VD4S**-*D2 -*** } with shuttle valve CA
 CB }
 CD } and vent valve VVV01

Subplate mounting

Pilot oil
 = internal from B
 and external from X
 Drain Y1
 = external out of the cap

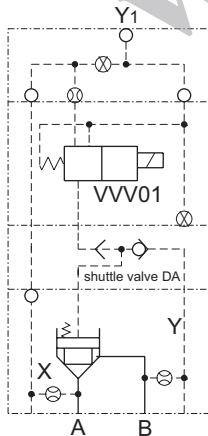

VD4S **-*C2 -*** } with shuttle valve DA
 DB }
 DD } and vent valve VVV01

Subplate mounting

Pilot oil
 = internal from A and B
 (B to A = Check valve
 function)
 Drain Y1
 = external out of the cap

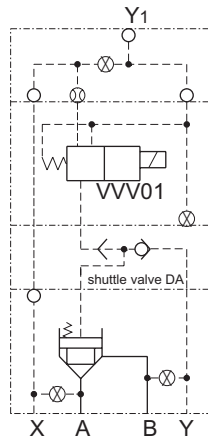

VD4S**-*B2 -*** } with shuttle valve DA
 DB }
 DD } and vent valve VVV01

Subplate mounting

Pilot oil
 = external from X and Y1
 Drain Y1
 = external out of the cap

Subplate mounting

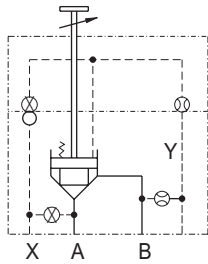

VD4S**-*D4 - 34* with stroke limiter
Pilot oil Y = internal from B
Note: for VD4S06 & VD4S10 only

Subplate mounting

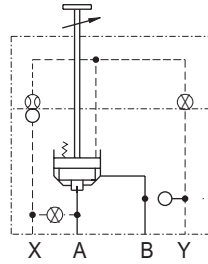

VD4S**-*23-3B* with stroke limiter
Pilot oil X = external
Note: for VD4S06 & VD4S10 only

Threaded body

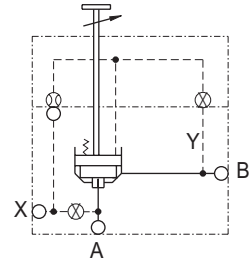

**ORDERING CODE EXAMPLE FOR
VERSION WITH VENT VALVE VVV01**

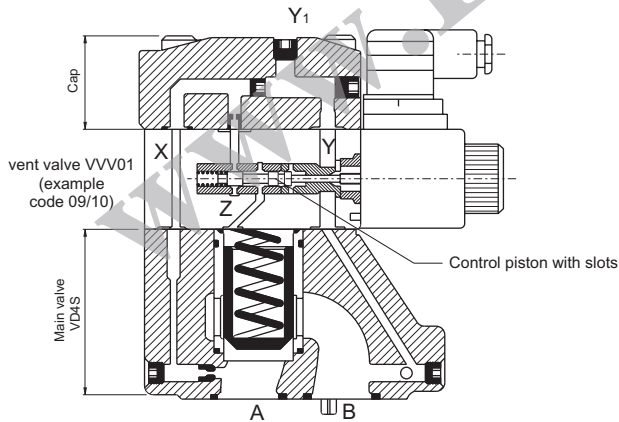

Function :

Pilot pressure from X → Z blocks the 2/2 - way valve VD4S.
Drain from Z → Y effects free flow from A → B or B → A.
Port X and Y can be connected internally or externally (refer to pilot line).
When port B is pressurised cap code 2 must be ordered.
Port Y in VVV01 then must be plugged.

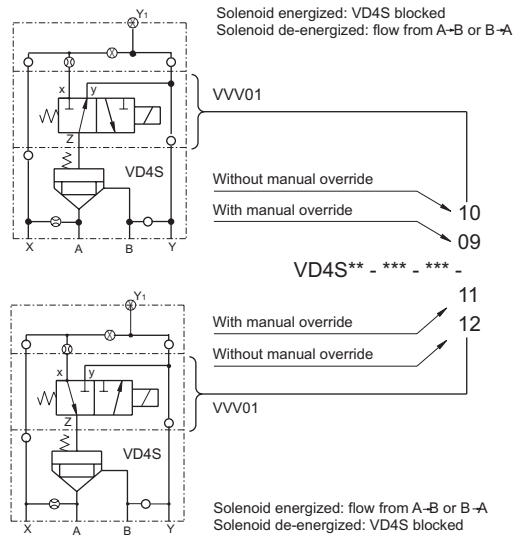

VD4S03 (3/8") SUBPLATE MOUNTING BODY (#3 & #9)

Weight : 5.93 lbs (2.7 kg)

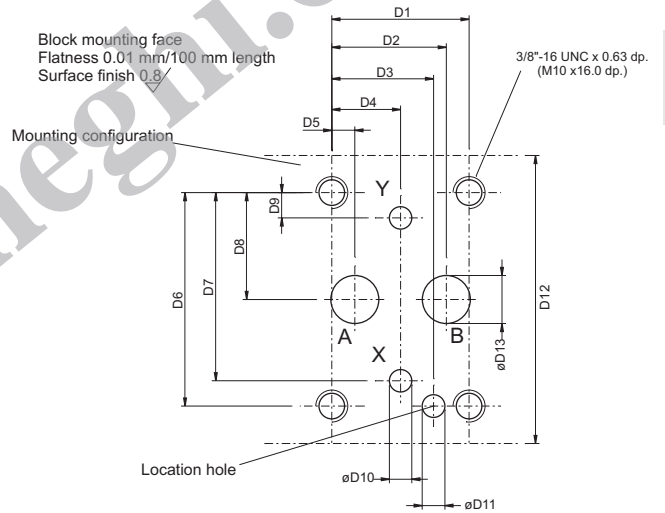
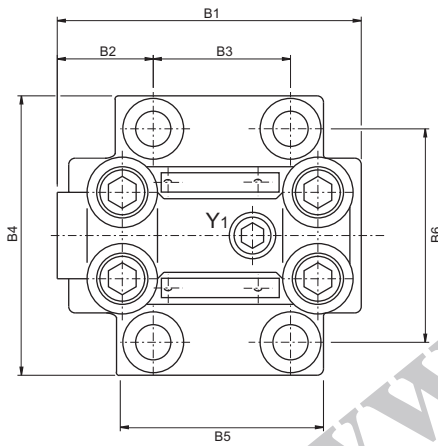
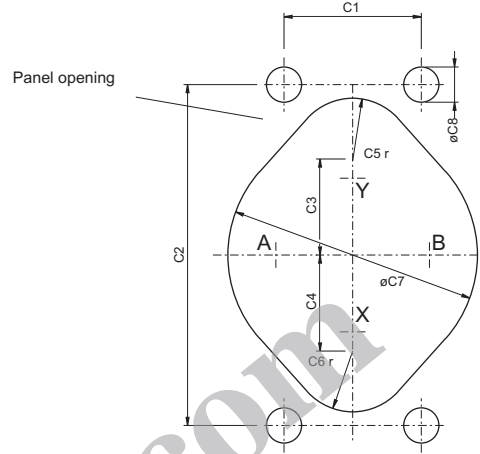
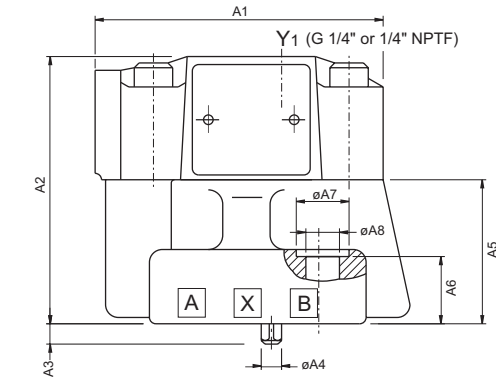

Dimensions		
	in	mm
A1	3.544	90.0
A2	3.288	83.5
A3	0.25	6.35
A4	ø0.25	ø6.35
A5	1.772	45.0
A6	0.827	21.0
A7	ø0.65	ø16.5
A8	ø0.41	ø10.5

Dimensions		
	in	mm
B1	3.74	95.0
B2	1.18	30.0
B3	1.689	42.9
B4	3.437	87.3
B5	2.5	63.5
B6	2.626	66.7

Dimensions		
	in	mm
C1	1.69	42.9
C2	4.19	106.5
C3	1.18	30.0
C4	1.18	30.0
C5	0.75 r	19.0 r
C6	0.75 r	19.0 r
C7	ø3.07	ø78.0
C8	ø0.43	ø11.0

Dimensions		
	in	mm
D1	1.69	42.9
D2	1.41	35.8
D3	1.253	31.8
D4	0.846	21.5
D5	0.283	7.2
D6	2.626	66.7
D7	2.315	58.8
D8	1.315	33.4
D9	0.311	7.9
D10	ø0.275	ø7.0
D11	ø0.28 x 0.315 dp.	ø7.1 x 11.0 dp.
D12	3.543	90.0
D13	ø0.59	ø15.0

Ports	Function
A	Inlet or outlet
B	Outlet or inlet
X	External pilot port
Y(Y ₁)	External drain*

* only in connection with VVV01 optional from cap(Y₁) or subplate (Y)

Note : For details of Subplate & mtg. Screws please refer page 12



VD4S03 (3/8") SUBPLATE

Weight : 4.4 lbs (2.0 kg)

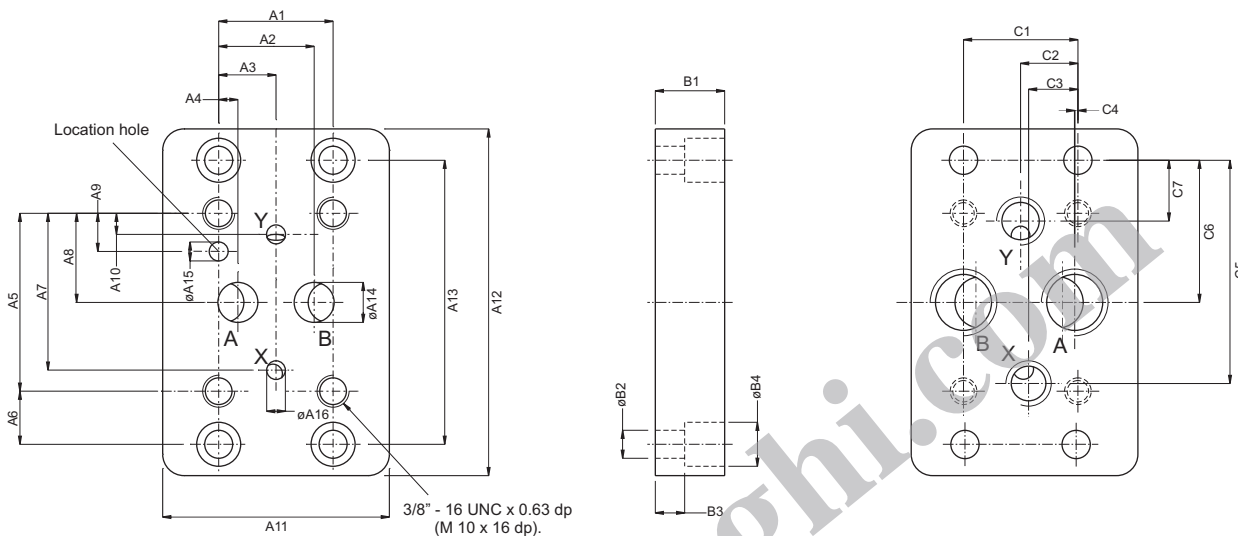

Dimensions	in		mm	
A1	1.69		42.9	
A2	1.41		35.8	
A3	0.846		21.5	
A4	0.283		7.2	
A5	2.626		66.7	
A6	0.783		19.9	
A7	2.315		58.8	
A8	1.315		33.4	
A9	0.563		14.3	
A10	0.311		7.9	
A11	3.346		85.0	
A12	5.12		130.0	
A13	4.19		106.5	
A14	ø0.59		ø15.0	
A15	ø0.28 x 0.315 dp.		ø7.1 x 8.0 dp.	
A16	ø0.275		ø7.0	

Dimensions	in		mm	
B1	1.024		26.0	
B2	ø0.41		ø10.5	
B3	0.433		11.0	
B4	ø0.65		ø16.5	

Dimensions	in		mm	
C1	1.69		42.9	
C2	0.846		21.5	
C3	0.73		18.5	
C4	0.047		1.2	
C5	3.295		83.7	
C6	2.1		53.3	
C7	0.9		22.8	

Order No.	Port sizes		Mounting screws* (4 numbers)		
	A+B	X+Y	Dimensions	Order No.	min.tensile strength
VSS - P - 08 - G 112	1/2" NPTF	1/4" NPTF	3/8" - 16UNC 1 1/4 lg.	V358 - 16180	at p ≤ 210 bar = 100 daN/mm ² (Torque 68 Nm)
VSS - B - 08 - G 113	1/2" B.S.P.P	1/4" B.S.P.P.	M10 x 35mm DIN 912 - 12.9	V700 - 70039	at p > 210 bar = 120 daN/mm ² (Torque 82 Nm)

* Mounting screws are included in subplate order.
For valves ordered without subplate, mounting screws must be ordered separately.

VD4S03 (3/8") - THREADED BODY (#1 & #6)

Weight : 7.03 lbs (3.2 kg)

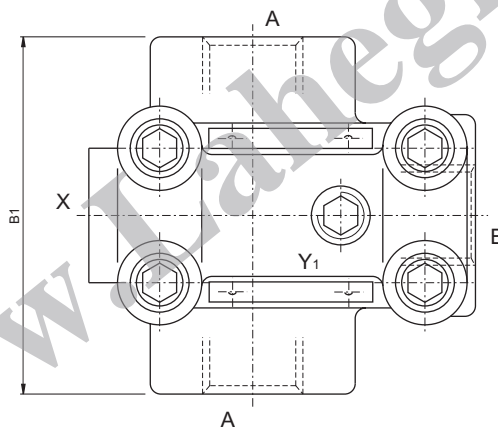
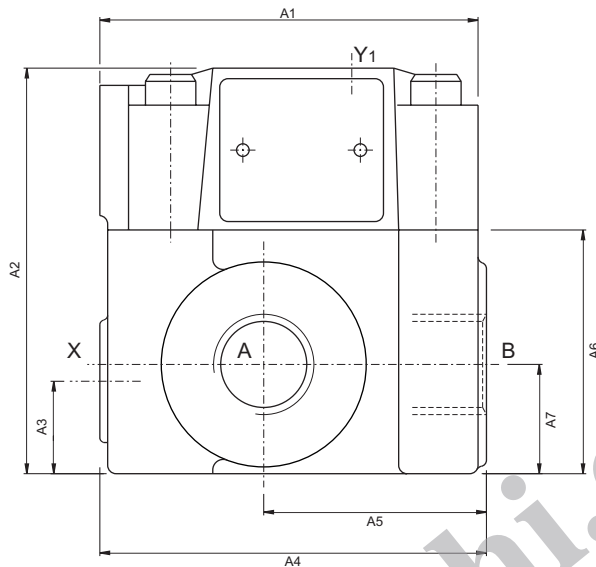

	Dimensions	
	in	mm
A1	3.544	90.0
A2	3.799	96.5
A3	0.866	22.0
A4	3.623	92.0
A5	2.087	53.0
A6	2.284	58.0
A7	1.024	26.0

	Dimensions	
	in	mm
B1	3.347	85.0

Ports	Function	Port sizes
A (2x)	Inlet or Outlet	1/2" B.S.P.P or 1/2" NPTF
B	Outlet or Inlet	
X	External pilot port	1/4" B.S.P.P. or 1/4" NPTF
Y1	External drain *	

*only in connection with VVV01

www.veljaneghi.com

SV